

F90A ECU Datasheet



For advanced and challenging applications, the F90A has a high pin count with up to 50 outputs and 44 inputs. The F90A ECU can be used for both DI (up to 10 cylinders in conjunction with an external GDI driver module) and non-DI (up to 12 cylinders) applications and with added new H-Bridge circuitry this ECU will directly control a high-pressure fuel pump and drive by wire throttles.

This twin processor unit uses a high-speed RISC processor for code execution and an additional large FPGA for high-speed engine position tracking, allowing the scheduling of code to be independent of signal patterns, increasing flexibility, efficiency and accuracy under transient conditions. This powerful combination also allows advanced control algorithms but yet easy to map for the end user.

The F90A is designed to control complex engines including, turbocharged, supercharged, twin drive by wire, quad cam, quad VVT, variable intake, GDI, gearbox, differential and many more! The unique crank and cam sync logger allow the flexibility of controlling the most awkward trigger patterns capable of running all current known patterns and even future OEM timing wheels.

All of this hardware is packaged within a lightweight CNC billet aluminium case with Autosport connectors. Designed to be installed in harsh Motorsport environments

Processing:

- Powerful RISC CPU for advanced strategy execution
- Custom synchronous FPGA processor for engine position tracking up to 25,000rpm

Outputs:

- 50 user configurable general purpose Pulse Width Modulated power outputs, including:
- 12 ignition coil outputs IGBT or TTL (software configurable)
- 24 general PWM/Fuel injector outputs
- 8 additional general PWM outputs pin shared with 8 analogue inputs (software configurable)
- 3 full bridges also configurable as 6 half bridges or 6 PWMs

Inputs:

- 28 user configurable general purpose analogue sensor inputs, including 16 bipolar, inductive or hall effect speed / engine position inputs
- 8 additional analogue inputs pin shared with general PWM outputs (software configurable)
- 8 dedicated inputs, including:
- 4 acoustic knock sensor inputs
- 2 wideband (NTK) lambda sensor interface
- 2 K-type thermocouple sensor interfaces

Interfaces:

- 100 MHz full duplex Ethernet for calibration, configuration and data download
- 3 CAN 2.0B interfaces for communication with other controllers or logging systems
- RS232 serial interface for communication with other controllers or logging systems

Memory:

- 128MB battery backed internal logging memory
- Ultra-Fast data download via Ethernet
- Time/Date stamped data via real time clock

Power Supply:

- 6V to 30V input voltage range with reverse polarity protection
- 2 regulated 5V sensor supply output with individual short circuit protection
- Software configurable (5V to 12V) sensor supply output (e.g. for 10V load cells)
- 5 Separately protected sensor and communication ground input

Physical:

- 3 Deutsch Autosport connectors with a total of 136 pins
- CNC machined sealed anodised aluminium case
- Maximum dimensions, including the connector, are 177mm x 172mm x 50.5mm
- Max operating temperature 85°C
- Total mass 1012 grams

Available Upgrade Features:

- Adaptive Knock Control
- Diesel Control
- Direct Injection Pump Control
- Direct Motor Control
- Gearbox Control
- Traction Control
- Custom Security

Ordering Information:

| Description | Part number |
|-------------------------------|-------------|
| F90A ECU | ECU-B02 |
| F90A Connector Kit | CON-A01 |
| Adaptive Knock Control | ECU-FEAT-K |
| Diesel Control | ECU-FEAT-D |
| Direct Injection Pump Control | ECU-FEAT-I |
| Direct Motor Control | ECU-FEAT-E |
| Gearbox Control | ECU-FEAT-G |
| Traction Control | ECU-FEAT-T |

Wiring Information:

Connector 1

Mating connector: AS616-26SA-HE

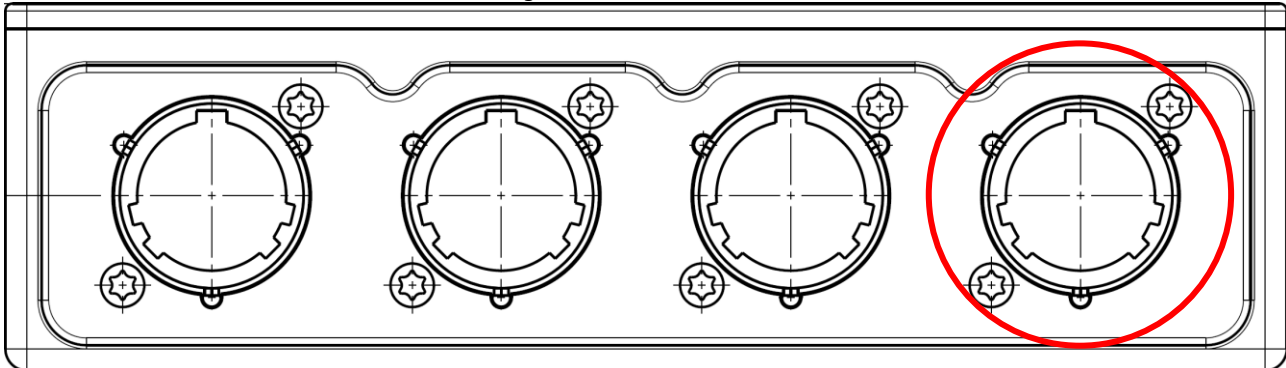

View looking at the front of an F90A highlighting connector 1 in red

| Pin | Gauge | Signal Name | Signal Notes |
|-----|----------|----------------|---|
| A | 20-24AWG | POWER GROUND | ECU negative, must be engine ground and as short as possible |
| B | 20-24AWG | POWER GROUND | ECU negative, must be engine ground and as short as possible |
| C | 20-24AWG | POWER GROUND | ECU negative, must be engine ground and as short as possible |
| D | 20-24AWG | POWER GROUND | ECU negative, must be engine ground and as short as possible |
| E | 20-24AWG | POWER GROUND | ECU negative, must be engine ground and as short as possible |
| F | 20-24AWG | POWER GROUND | ECU negative, must be engine ground and as short as possible |
| G | 20-24AWG | POWER GROUND | ECU negative, must be engine ground and as short as possible |
| H | 20-24AWG | IGNITION #01 | Ignition coil can be "NORMAL" or "TTL" (set via software) or low-side PWM |
| J | 20-24AWG | IGNITION #02 | Ignition coil can be "NORMAL" or "TTL" (set via software) or low-side PWM |
| K | 20-24AWG | IGNITION #03 | Ignition coil can be "NORMAL" or "TTL" (set via software) or low-side PWM |
| L | 20-24AWG | IGNITION #04 | Ignition coil can be "NORMAL" or "TTL" (set via software) or low-side PWM |
| M | 20-24AWG | IGNITION #05 | Ignition coil can be "NORMAL" or "TTL" (set via software) or low-side PWM |
| N | 20-24AWG | IGNITION #06 | Ignition coil can be "NORMAL" or "TTL" (set via software) or low-side PWM |
| P | 20-24AWG | IGNITION #07 | Ignition coil can be "NORMAL" or "TTL" (set via software) or low-side PWM |
| R | 20-24AWG | IGNITION #08 | Ignition coil can be "NORMAL" or "TTL" (set via software) or low-side PWM |
| S | 20-24AWG | IGNITION #09 | Ignition coil can be "NORMAL" or "TTL" (set via software) or low-side PWM |
| T | 20-24AWG | IGNITION #10 | Ignition coil can be "NORMAL" or "TTL" (set via software) or low-side PWM |
| U | 20-24AWG | IGNITION #11 | Ignition coil can be "NORMAL" or "TTL" (set via software) or low-side PWM |
| V | 20-24AWG | IGNITION #12 | Ignition coil can be "NORMAL" or "TTL" (set via software) or low-side PWM |
| W | 20-24AWG | BATTERY SUPPLY | ECU positive, must be as short as possible |
| X | 20-24AWG | BATTERY SUPPLY | ECU positive, must be as short as possible |
| Y | 20-24AWG | BATTERY SUPPLY | ECU positive, must be as short as possible |
| Z | 20-24AWG | BATTERY SUPPLY | ECU positive, must be as short as possible |
| a | 20-24AWG | BATTERY SUPPLY | ECU positive, must be as short as possible |
| b | 20-24AWG | BATTERY SUPPLY | ECU positive, must be as short as possible |
| c | 20-24AWG | BATTERY SUPPLY | ECU positive, must be as short as possible |

Connector 2

Mating connector: AS616-35SN-HE

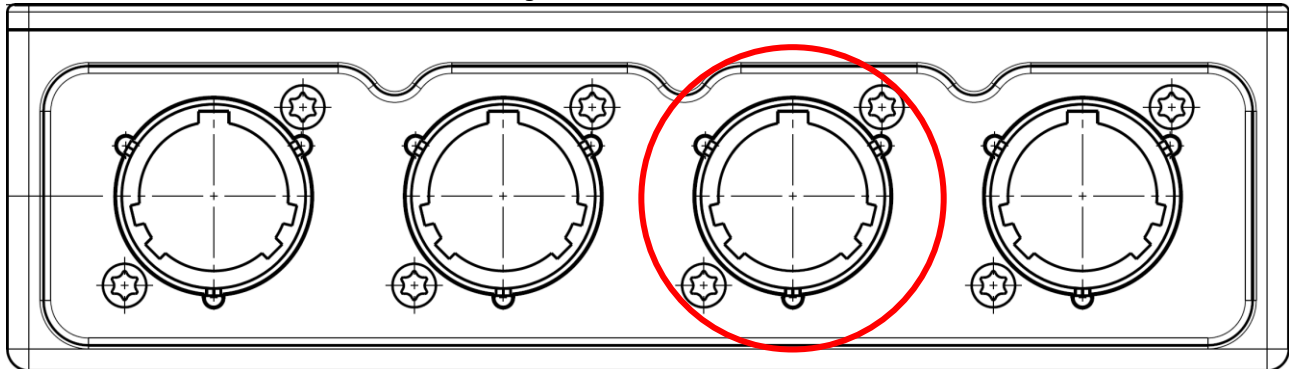

View looking at the front of an F90A highlighting connector 2 in red

| Pin | Gauge | Signal Name | Software I/O assignment | Signal Notes |
|-----|----------|-------------------|-------------------------|--|
| 1 | 22-26AWG | 5V OUT #01 | N/A | Regulated 5V sensor supply rail, maximum current capability of 100mA |
| 2 | 22-26AWG | 5V OUT #02 | N/A | Regulated 5V sensor supply rail, maximum current capability of 100mA |
| 3 | 22-26AWG | 10V OUT | N/A | Variable voltage supply pin, maximum current capability of 15mA |
| 4 | 22-26AWG | 12V OUT | N/A | Battery out |
| 5 | 22-26AWG | LAN TX- | N/A | Ethernet PC communication port |
| 6 | 22-26AWG | LAN TX+ | N/A | Ethernet PC communication port |
| 7 | 22-26AWG | LAN RX- | N/A | Ethernet PC communication port |
| 8 | 22-26AWG | LAN RX+ | N/A | Ethernet PC communication port |
| 9 | 22-26AWG | CAN LO #01 | N/A | CAN communication port 120Ω terminated |
| 10 | 22-26AWG | CAN HI #01 | N/A | CAN communication port 120Ω terminated |
| 11 | 22-26AWG | LAMBDA V #01 | LAMBDA V #01 | Lambda voltage signal [Vs] |
| 12 | 22-26AWG | LAMBDA I #01 | N/A | Lambda current pump [Ip] |
| 13 | 22-26AWG | LAMBDA GROUND | N/A | Lambda ground [Vs/Ip] |
| 14 | 22-26AWG | LAMBDA V #02 | LAMBDA V #02 | Lambda voltage signal [Vs] |
| 15 | 22-26AWG | LAMBDA I #02 | N/A | Lambda current pump [Ip] |
| 16 | 22-26AWG | THERMO+ #01 | THERMO+ #01 | Thermocouple positive [K-Type] |
| 17 | 22-26AWG | THERMO- #01 | N/A | Thermocouple positive [K-Type] |
| 18 | 22-26AWG | THERMO+ #02 | THERMO+ #02 | Thermocouple positive [K-Type] |
| 19 | 22-26AWG | THERMO- #02 | N/A | Thermocouple positive [K-Type] |
| 20 | 22-26AWG | INPUT #01 (GEN) | AN #01 | Generic input; analogue or frequency; 0-5V, -5V to +5V, 47kΩ (software pullup) |
| 21 | 22-26AWG | INPUT #02 (GEN) | AN #02 | Generic input; analogue or frequency; 0-5V, -5V to +5V, 3kΩ (software pullup) |
| 22 | 22-26AWG | SENSOR GROUND #01 | N/A | Protected sensor ground |
| 23 | 22-26AWG | INPUT #03 (GEN) | AN #03 | Generic input; analogue or frequency; 0-5V, -5V to +5V, 3kΩ (software pullup) |
| 24 | 22-26AWG | INPUT #04 (GEN) | AN #04 | Generic input; analogue or frequency; 0-5V, -5V to +5V, 3kΩ (software pullup) |
| 25 | 22-26AWG | SENSOR GROUND #02 | N/A | Protected sensor ground |
| 26 | 22-26AWG | INPUT #05 (GEN) | AN #05 | Generic input; analogue or frequency; 0-5V, -5V to +5V, 3kΩ (software pullup) |
| 27 | 22-26AWG | INPUT #06 (GEN) | AN #06 | Generic input; analogue or frequency; 0-5V, -5V to +5V, 3kΩ (software pullup) |
| 28 | 22-26AWG | SENSOR GROUND #01 | N/A | Protected sensor ground |
| 29 | 22-26AWG | INPUT #07 (GEN) | AN #07 | Generic input; analogue or frequency; 0-5V, -5V to +5V, 3kΩ (software pullup) |
| 30 | 22-26AWG | INPUT #08 (GEN) | AN #08 | Generic input; analogue or frequency; 0-5V, -5V to +5V, 3kΩ (software pullup) |
| 31 | 22-26AWG | SENSOR GROUND #02 | N/A | Protected sensor ground |
| 32 | 22-26AWG | INPUT #09 (GEN) | AN #09 | Generic input; analogue or frequency; 0-5V, -5V to +5V, 3kΩ (software pullup) |
| 33 | 22-26AWG | INPUT #10 (GEN) | AN #10 | Generic input; analogue or frequency; 0-5V, -5V to +5V, 3kΩ (software pullup) |
| 34 | 22-26AWG | SENSOR GROUND #01 | N/A | Protected sensor ground |
| 35 | 22-26AWG | INPUT #11 (GEN) | AN #11 | Generic input; analogue or frequency; 0-5V, -5V to +5V, 3kΩ (software pullup) |
| 36 | 22-26AWG | INPUT #12 (GEN) | AN #12 | Generic input; analogue or frequency; 0-5V, -5V to +5V, 3kΩ (software pullup) |
| 37 | 22-26AWG | SENSOR GROUND #02 | N/A | Protected sensor ground |
| 38 | 22-26AWG | INPUT #13 (GEN) | AN #13 | Generic input; analogue or frequency; 0-5V, -5V to +5V, 3kΩ (software pullup) |
| 39 | 22-26AWG | INPUT #14 (GEN) | AN #14 | Generic input; analogue or frequency; 0-5V, -5V to +5V, 3kΩ (software pullup) |
| 40 | 22-26AWG | SENSOR GROUND #01 | N/A | Protected sensor ground |

| | | | | |
|----|----------|-------------------|--------|---|
| 41 | 22-26AWG | INPUT #15 (GEN) | AN #15 | Generic input; analogue or frequency; 0-5V, -5V to +5V, 3kΩ (software pullup) |
| 42 | 22-26AWG | INPUT #16 (GEN) | AN #16 | Generic input; analogue or frequency; 0-5V, -5V to +5V, 3kΩ (software pullup) |
| 43 | 22-26AWG | SENSOR GROUND #02 | N/A | Protected sensor ground |
| 44 | 22-26AWG | INPUT #17 (5V) | AN #17 | Analogue input 0-5V |
| 45 | 22-26AWG | INPUT #18 (5V) | AN #18 | Analogue input 0-5V |
| 46 | 22-26AWG | SENSOR GROUND #01 | N/A | Protected sensor ground |
| 47 | 22-26AWG | INPUT #19 (5V) | AN #19 | Analogue input 0-5V |
| 48 | 22-26AWG | INPUT #20 (5V) | AN #20 | Analogue input 0-5V |
| 49 | 22-26AWG | SENSOR GROUND #02 | N/A | Protected sensor ground |
| 50 | 22-26AWG | INPUT #21 (TH) | AN #21 | Thermistor input; analogue 0-5V with fixed 3kΩ pullup to 5V |
| 51 | 22-26AWG | INPUT #22 (TH) | AN #22 | Thermistor input; analogue 0-5V with fixed 3kΩ pullup to 5V |
| 52 | 22-26AWG | SENSOR GROUND #01 | N/A | Protected sensor ground |
| 53 | 22-26AWG | INPUT #23 (TH) | AN #23 | Thermistor input; analogue 0-5V with fixed 3kΩ pullup to 5V |
| 54 | 22-26AWG | INPUT #24 (TH) | AN #24 | Thermistor input; analogue 0-5V with fixed 3kΩ pullup to 5V |
| 55 | 22-26AWG | SENSOR GROUND #02 | N/A | Protected sensor ground |

Connector 3

Mating connector: AS616-35SB-HE

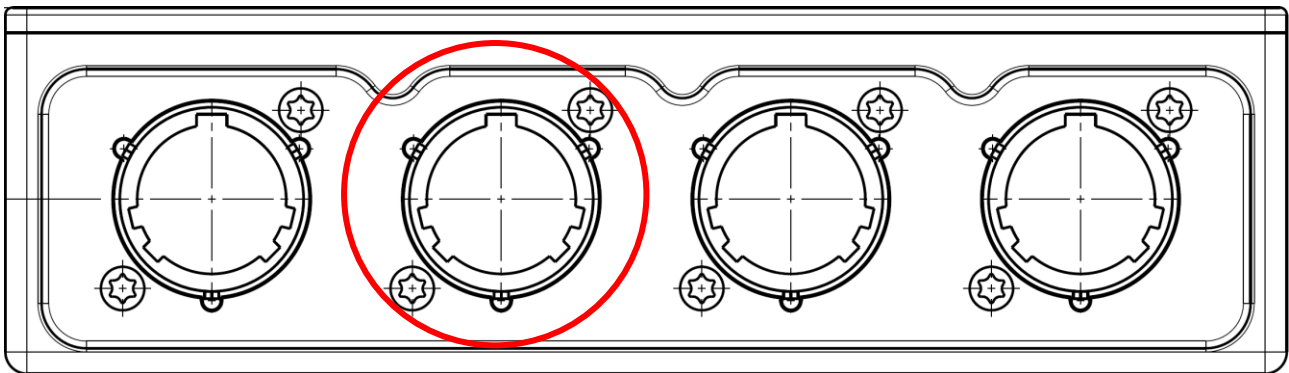

View looking at the front of an F90A highlighting connector 3 in red

| Pin | Gauge | Signal Name | Software I/O assignment | Signal Notes |
|-----|----------|----------------|-------------------------|--|
| 1 | 22-26AWG | DO NOT CONNECT | N/A | LR internal use |
| 2 | 22-26AWG | DO NOT CONNECT | N/A | LR internal use |
| 3 | 22-26AWG | CAN LO #03 | N/A | CAN communication port 120Ω terminated |
| 4 | 22-26AWG | CAN HI #03 | N/A | CAN communication port 120Ω terminated |
| 5 | 22-26AWG | DO NOT CONNECT | N/A | LR internal use |
| 6 | 22-26AWG | DO NOT CONNECT | N/A | LR internal use |
| 7 | 22-26AWG | DO NOT CONNECT | N/A | LR internal use |
| 8 | 22-26AWG | DO NOT CONNECT | N/A | LR internal use |
| 9 | 22-26AWG | DO NOT CONNECT | N/A | LR internal use |
| 10 | 22-26AWG | DO NOT CONNECT | N/A | LR internal use |
| 11 | 22-26AWG | DO NOT CONNECT | N/A | LR internal use |
| 12 | 22-26AWG | DO NOT CONNECT | N/A | LR internal use |
| 13 | 22-26AWG | DO NOT CONNECT | N/A | LR internal use |
| 14 | 22-26AWG | DO NOT CONNECT | N/A | LR internal use |
| 15 | 22-26AWG | DO NOT CONNECT | N/A | LR internal use |
| 16 | 22-26AWG | DO NOT CONNECT | N/A | LR internal use |
| 17 | 22-26AWG | DO NOT CONNECT | N/A | LR internal use |
| 18 | 22-26AWG | DO NOT CONNECT | N/A | LR internal use |
| 19 | 22-26AWG | DO NOT CONNECT | N/A | LR internal use |
| 20 | 22-26AWG | DO NOT CONNECT | N/A | LR internal use |
| 21 | 22-26AWG | DO NOT CONNECT | N/A | LR internal use |
| 22 | 22-26AWG | DO NOT CONNECT | N/A | LR internal use |

| | | | | |
|----|----------|--------------------------|-----------|--|
| 23 | 22-26AWG | DO NOT CONNECT | N/A | LR internal use |
| 24 | 22-26AWG | DO NOT CONNECT | N/A | LR internal use |
| 25 | 22-26AWG | DO NOT CONNECT | N/A | LR internal use |
| 26 | 22-26AWG | DO NOT CONNECT | N/A | LR internal use |
| 27 | 22-26AWG | DO NOT CONNECT | N/A | LR internal use |
| 28 | 22-26AWG | DO NOT CONNECT | N/A | LR internal use |
| 29 | 22-26AWG | DO NOT CONNECT | N/A | LR internal use |
| 30 | 22-26AWG | DO NOT CONNECT | N/A | LR internal use |
| 31 | 22-26AWG | DO NOT CONNECT | N/A | LR internal use |
| 32 | 22-26AWG | DO NOT CONNECT | N/A | LR internal use |
| 33 | 22-26AWG | DO NOT CONNECT | N/A | LR internal use |
| 34 | 22-26AWG | DO NOT CONNECT | N/A | LR internal use |
| 35 | 22-26AWG | DO NOT CONNECT | N/A | LR internal use |
| 36 | 22-26AWG | DO NOT CONNECT | N/A | LR internal use |
| 37 | 22-26AWG | DO NOT CONNECT | N/A | LR internal use |
| 38 | 22-26AWG | KNOCK #01 ⁽¹⁾ | KNOCK #01 | Knock sensor input |
| 39 | 22-26AWG | KNOCK #02 ⁽¹⁾ | KNOCK #02 | Knock sensor input |
| 40 | 22-26AWG | KNOCK GROUND | N/A | Knock sensor ground |
| 41 | 22-26AWG | KNOCK #03 ⁽¹⁾ | KNOCK #03 | Knock sensor input |
| 42 | 22-26AWG | KNOCK #04 ⁽¹⁾ | KNOCK #04 | Knock sensor input |
| 43 | 22-26AWG | KNOCK GROUND | N/A | Knock sensor ground |
| 44 | 22-26AWG | CAN LO #02 | N/A | CAN communication port 120Ω terminated |
| 45 | 22-26AWG | CAN HI #02 | N/A | CAN communication port 120Ω terminated |
| 46 | 22-26AWG | DO NOT CONNECT | N/A | LR internal use |
| 47 | 22-26AWG | DO NOT CONNECT | N/A | LR internal use |
| 48 | 22-26AWG | DO NOT CONNECT | N/A | LR internal use |
| 49 | 22-26AWG | DO NOT CONNECT | N/A | LR internal use |
| 50 | 22-26AWG | DO NOT CONNECT | N/A | LR internal use |
| 51 | 22-26AWG | DO NOT CONNECT | N/A | LR internal use |
| 52 | 22-26AWG | DO NOT CONNECT | N/A | LR internal use |
| 53 | 22-26AWG | DO NOT CONNECT | N/A | LR internal use |
| 54 | 22-26AWG | DO NOT CONNECT | N/A | LR internal use |
| 55 | 22-26AWG | DO NOT CONNECT | N/A | LR internal use |

Connector 4

Mating connector: AS616-35SD-HE

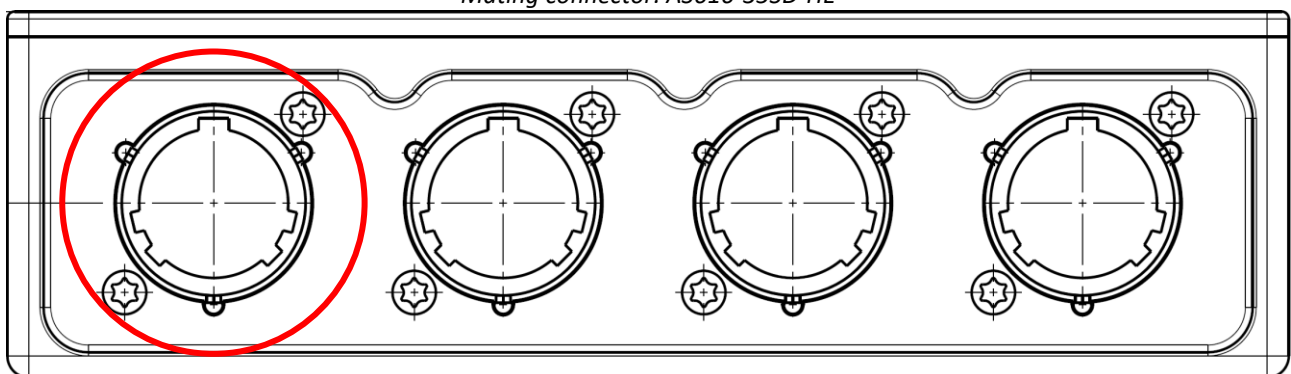

View looking at the front of an F90A highlighting connector 3 in red

| Pin | Gauge | Signal Name | Signal Notes |
|-----|----------|-------------|---|
| 1 | 22-26AWG | FUEL #01 | Port fuel injector or low-side PWM 10A peak |
| 2 | 22-26AWG | FUEL #02 | Port fuel injector or low-side PWM 10A peak |
| 3 | 22-26AWG | FUEL #03 | Port fuel injector or low-side PWM 10A peak |
| 4 | 22-26AWG | FUEL #04 | Port fuel injector or low-side PWM 10A peak |
| 5 | 22-26AWG | FUEL #05 | Port fuel injector or low-side PWM 10A peak |
| 6 | 22-26AWG | FUEL #06 | Port fuel injector or low-side PWM 10A peak |
| 7 | 22-26AWG | FUEL #07 | Port fuel injector or low-side PWM 10A peak |
| 8 | 22-26AWG | FUEL #08 | Port fuel injector or low-side PWM 10A peak |
| 9 | 22-26AWG | FUEL #09 | Port fuel injector or low-side PWM 10A peak |
| 10 | 22-26AWG | FUEL #10 | Port fuel injector or low-side PWM 10A peak |

| | | | |
|----|----------|---------------------|--|
| 11 | 22-26AWG | FUEL #11 | Port fuel injector or low-side PWM 10A peak |
| 12 | 22-26AWG | FUEL #12 | Port fuel injector or low-side PWM 10A peak |
| 13 | 22-26AWG | FUEL #13 | Port fuel injector or low-side PWM 10A peak |
| 14 | 22-26AWG | FUEL #14 | Port fuel injector or low-side PWM 10A peak |
| 15 | 22-26AWG | FUEL #15 | Port fuel injector or low-side PWM 10A peak |
| 16 | 22-26AWG | FUEL #16 | Port fuel injector or low-side PWM 10A peak |
| 17 | 22-26AWG | FUEL #17 | Port fuel injector or low-side PWM 10A peak |
| 18 | 22-26AWG | FUEL #18 | Port fuel injector or low-side PWM 10A peak |
| 19 | 22-26AWG | FUEL #19 | Port fuel injector or low-side PWM 10A peak |
| 20 | 22-26AWG | FUEL #20 | Port fuel injector or low-side PWM 10A peak |
| 21 | 22-26AWG | FUEL #21 | Port fuel injector or low-side PWM 10A peak |
| 22 | 22-26AWG | FUEL #22 | Port fuel injector or low-side PWM 10A peak |
| 23 | 22-26AWG | FUEL #23 | Port fuel injector or low-side PWM 10A peak |
| 24 | 22-26AWG | FUEL #24 | Port fuel injector or low-side PWM 10A peak |
| 25 | 22-26AWG | H-BRIDGE #04 | H-bridge, low-side PWM or full bridge ⁽¹⁾ , 20A peak |
| 26 | 22-26AWG | H-BRIDGE #03 | H-bridge, low-side PWM or full bridge ⁽¹⁾ , 20A peak |
| 27 | 22-26AWG | H-BRIDGE #02 | H-bridge, low-side PWM or full bridge ⁽¹⁾ , 20A peak |
| 28 | 22-26AWG | H-BRIDGE #01 | H-bridge, low-side PWM or full bridge ⁽¹⁾ , 20A peak |
| 29 | 22-26AWG | DO NOT CONNECT | LR Internal use |
| 30 | 22-26AWG | DO NOT CONNECT | LR Internal use |
| 31 | 22-26AWG | H-BRIDGE #06 | H-bridge, low-side PWM or full bridge ⁽¹⁾ , 20A peak |
| 32 | 22-26AWG | H-BRIDGE #05 | H-bridge, low-side PWM or full bridge ⁽¹⁾ , 20A peak |
| 33 | 22-26AWG | PWM #01 / INPUT #29 | low-side PWM 10A or Analogue input 0-5V (software selectable) |
| 34 | 22-26AWG | PWM #02 / INPUT #30 | low-side PWM 10A or Analogue input 0-5V (software selectable) |
| 35 | 22-26AWG | PWM #03 / INPUT #31 | low-side PWM 10A or Analogue input 0-5V (software selectable) |
| 36 | 22-26AWG | PWM #04 / INPUT #32 | low-side PWM 10A or Analogue input 0-5V (software selectable) |
| 37 | 22-26AWG | PWM #05 / INPUT #33 | low-side PWM 10A or Analogue input 0-5V (software selectable) |
| 38 | 22-26AWG | PWM #06 / INPUT #34 | low-side PWM 10A or Analogue input 0-5V (software selectable) |
| 39 | 22-26AWG | PWM #07 / INPUT #35 | low-side PWM 10A or Analogue input 0-5V (software selectable) |
| 40 | 22-26AWG | PWM #08 / INPUT #36 | low-side PWM 10A or Analogue input 0-5V (software selectable) |
| 41 | 22-26AWG | INPUT #25 | Analogue input 0-5V |
| 42 | 22-26AWG | INPUT #26 | Analogue input 0-5V |
| 43 | 22-26AWG | INPUT #27 | Analogue input 0-5V |
| 44 | 22-26AWG | INPUT #28 | Analogue input 0-5V |
| 45 | 22-26AWG | DO NOT CONNECT | LR Internal use |
| 46 | 22-26AWG | DO NOT CONNECT | LR Internal use |
| 47 | 22-26AWG | DO NOT CONNECT | LR Internal use |
| 48 | 22-26AWG | DO NOT CONNECT | LR Internal use |
| 49 | 22-26AWG | 5V OUT #01 | Regulated 5V sensor supply rail, maximum current capability of 100mA |
| 50 | 22-26AWG | 12V OUT | Battery out |
| 51 | 22-26AWG | DO NOT CONNECT | LR Internal use |
| 52 | 22-26AWG | DO NOT CONNECT | LR Internal use |
| 53 | 22-26AWG | RS232 TX | RS232 transmit |
| 54 | 22-26AWG | SENSOR GROUND #01 | Protected sensor ground |
| 55 | 22-26AWG | RS232 RX | RS232 receive |

Footnotes:

⁽¹⁾Relevant upgrade feature must be enabled

Dimensions:

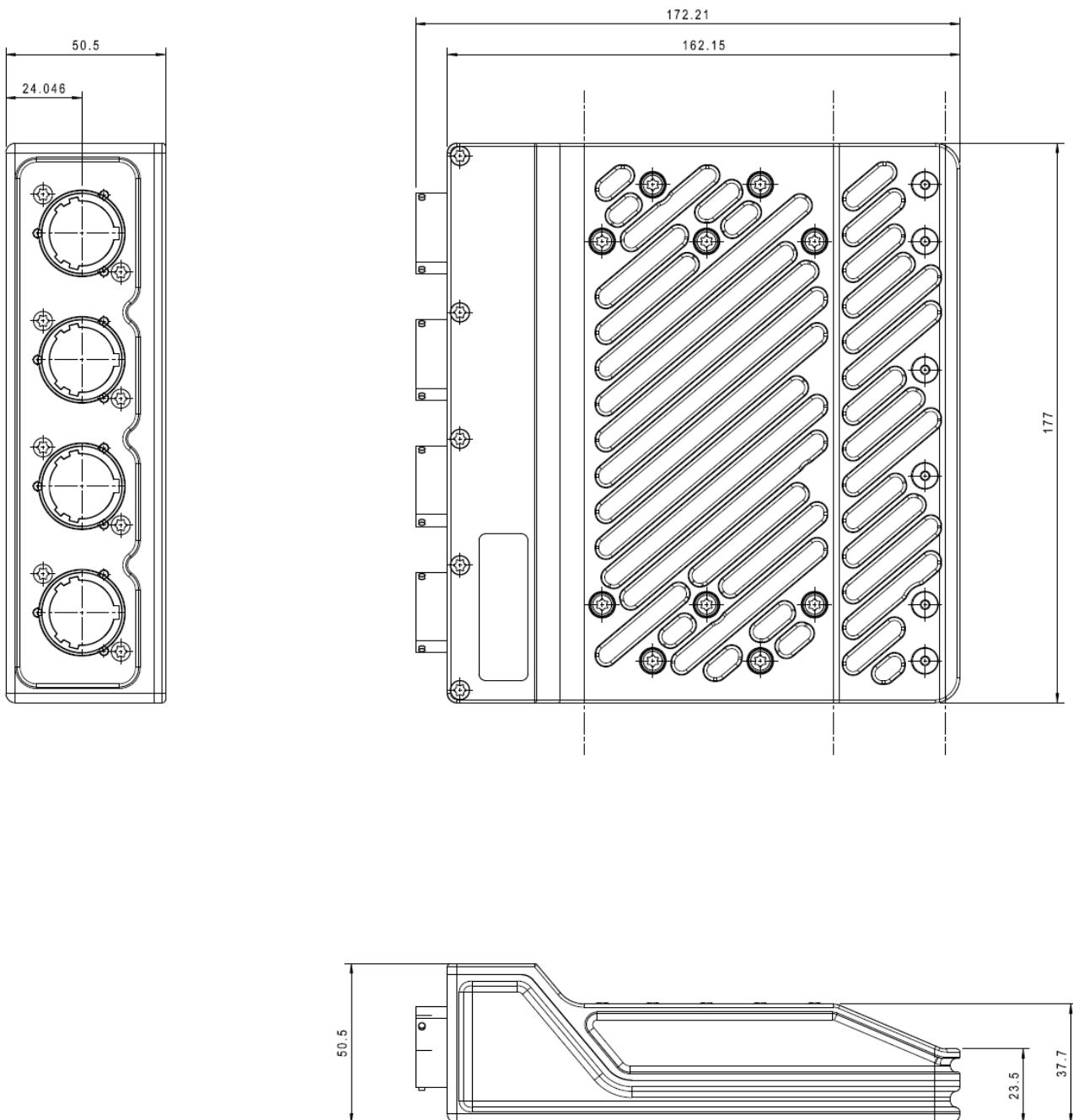

Warranty and Servicing:

- This equipment comes with a 1 year warranty against manufacturing defects and failures however misuse or damage will not be covered under warranty.
- Warranty may be extended on an annual basis via a system refurbishment scheme.
- This ECU contains a battery which can be returned to Life Racing for a replacement, a charge may be made for this service.