

F88 R-Series ECU Datasheet



The F88R/RS/RX range has been specifically designed for applications where cost is paramount. These ECUs incorporate the same control strategies and processing power as the F88 however unnecessary hardware components have been removed so that the overall cost can be reduced for users who do not require the vast amount of I/O the F88 utilises.

This twin processor unit uses a high speed RISC processor for code execution and an additional large FPGA for high speed engine position tracking, allowing scheduling code to be independent of signal patterns thus increasing flexibility, efficiency and accuracy under transient conditions. This powerful combination also allows advanced control algorithms yet remains easy to calibrate for the end user.

The F88 R-Series is designed to control complex modern port fuel injected engines. Standard strategies include, turbocharged, supercharged, drive by wire, quad vvt, vtec, gearbox, differential and many more. The internal data logging coupled with a unique crank and cam sync logger allows detailed analysis of inputs, control signals and fault diagnosis.

This powerful hardware is packaged within a lightweight high pressure die cast aluminium case designed to be installed in harsh motorsport environments.

Processing:

- Powerful RISC CPU for advanced strategy execution
- Custom synchronous FPGA processor for engine position tracking up to 25,000rpm

Outputs:

- Up to 26 user configurable general purpose Pulse Width Modulated power outputs, including:
- Up to 6 ignition coil outputs IGBT or TTL (Software configurable)
- Up to 16 general PWM/Fuel injector outputs
- Up to 2 full bridges also configurable as 4 half bridges or 4 PWMs (DbW)

Inputs:

- 24 user configurable general purpose analogue sensor inputs, including up to 8 bipolar, inductive or hall effect speed / engine position inputs
- Up to 4 dedicated inputs, including:
- Optional 2 acoustic knock sensor inputs
- Up to 2 wideband (NTK) lambda sensor interface

Interfaces:

- 100 MHz full duplex Ethernet for calibration, configuration and data download
- 2 CAN 2.0B interfaces for communication with other controllers or logging systems
- RS232 serial interface for communication with other controllers or logging systems

Memory:

- 32MB[R & RS] or 64MB[RX] battery backed internal logging memory
- Ultra-Fast data download via Ethernet
- Time/Date stamped data via real time clock

Power Supply:

- 6V to 30V input voltage range with reverse polarity protection
- 2 regulated 5V sensor supply output with individual short circuit protection
- 5 Separately protected sensor and communication ground input

Physical:

- 88 way Bosch / AMP sealed connector
- Sealed high pressure die cast black powder coated aluminium case
- Maximum dimension including the connector is 183mm x 125mm x 36mm
- Max operating temperature 85°C
- Total mass 480 grams

Available Upgrade Features:

- Direct Motor Control
- Gearbox Control
- Traction Control
- Custom Security

Build Time Choice (BTC) Options:

- 6 Ignition Outputs
- 8 Frequency Inputs
- Adaptive Knock Control
- CAN3 Replaces Second Lambda
- Second Lambda Input

R-Series Model Comparison:

FEATURE/ECU	F88R ECU	F88RS ECU	F88RX ECU
Configurable Inputs	24	24	24
PWM/Injector Outputs	8	12	16
Memory	32MB	32MB	64MB

Ordering Information:

Description	Part number
F88R ECU	ECU-A04
F88RS ECU	ECU-A03
R88RX ECU	ECU-A02
88Way Connector Kit	CON-B01
6 Ignition Outputs	ECU-BTC-6I
8 Frequency Inputs	ECU-BTC-8F
Adaptive Knock Control	ECU-FEAT-K
CAN3 Replaces Second Lambda	ECU-BTC-3C
Direct Motor Control	ECU-FEAT-E
Gearbox Control	ECU-FEAT-G
Second Lambda Input	ECU-BTC-2L
Traction Control	ECU-FEAT-T

Wiring Information:

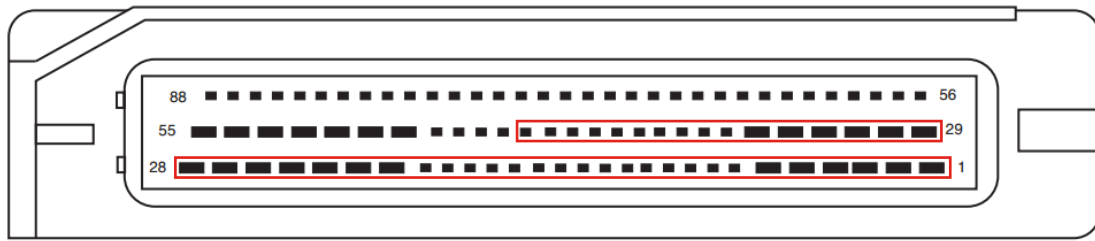

View looking into the 88 way connector highlighting pins 1-44 in red

Pin	Gauge	Signal Name	Signal Notes
1	18AWG	POWER GROUND	ECU negative, must be engine ground and as short as possible
2	-	DO NOT CONNECT	-
3	-	DO NOT CONNECT	-
4	20AWG	IGNITION #06 ⁽¹⁾	Ignition coil can be "NORMAL" or "TTL" (set via software) or low-side PWM
5	20AWG	IGNITION #05 ⁽¹⁾	Ignition coil can be "NORMAL" or "TTL" (set via software) or low-side PWM
6	22AWG	FUEL #10 ⁽²⁾	Port fuel injector or low-side PWM 10A peak
7	24AWG	KNOCK #02 ⁽⁴⁾	BTC Knock sensor input
8	24AWG	INPUT #16 ⁽¹⁾	Generic input; analogue or frequency ⁽¹⁾ ; 0-5V, -5V to +5V, 3kΩ (software pullup)
9	24AWG	INPUT #14 ⁽¹⁾	Generic input; analogue or frequency ⁽¹⁾ ; 0-5V, -5V to +5V, 3kΩ (software pullup)
10	24AWG	INPUT #12	Generic input; analogue or frequency; 0-5V, -5V to +5V, 3kΩ (software pullup)
11	24AWG	INPUT #10	Generic input; analogue or frequency; 0-5V, -5V to +5V, 3kΩ (software pullup)
12	-	DO NOT CONNECT	-
13	-	DO NOT CONNECT	-
14	24AWG	INPUT #07	Analogue input 0-5V, 3kΩ software pullup to 5V
15	24AWG	INPUT #05	Analogue input 0-5V, 3kΩ software pullup to 5V
16	24AWG	INPUT #03	Analogue input 0-5V, 3kΩ software pullup to 5V
17	24AWG	INPUT #01	Analogue input 0-5V, 47kΩ software pullup to 5V
18	24AWG	LAMBDA V #01	Lambda voltage signal [Vs]
19	24AWG	INPUT #21	Thermistor input; analogue 0-5V with fixed 3kΩ pullup to 5V
20	22AWG	FUEL #15 ^{(2) (3)}	Port fuel injector or low-side PWM 10A peak
21	24AWG	RS232 TX	RS232 transmit
22	22AWG	FUEL #07	Port fuel injector or low-side PWM 10A peak
23	22AWG	FUEL #05	Port fuel injector or low-side PWM 10A peak
24	20AWG	IGNITION #04	Ignition coil can be "NORMAL" or "TTL" (set via software) or low-side PWM
25	20AWG	IGNITION #03	Ignition coil can be "NORMAL" or "TTL" (set via software) or low-side PWM
26	20AWG	IGNITION #02	Ignition coil can be "NORMAL" or "TTL" (set via software) or low-side PWM
27	20AWG	IGNITION #01	Ignition coil can be "NORMAL" or "TTL" (set via software) or low-side PWM
28	18AWG	POWER GROUND	ECU negative, must be engine ground and as short as possible
29	18AWG	POWER GROUND	ECU negative, must be engine ground and as short as possible
30	22AWG	FUEL #14 ^{(2) (3)}	Port fuel injector or low-side PWM 10A peak
31	22AWG	FUEL #13 ^{(2) (3)}	Port fuel injector or low-side PWM 10A peak
32	22AWG	FUEL #12 ⁽²⁾	Port fuel injector or low-side PWM 10A peak
33	22AWG	FUEL #11 ⁽²⁾	Port fuel injector or low-side PWM 10A peak
34	22AWG	FUEL #09 ⁽²⁾	Port fuel injector or low-side PWM 10A peak
35	24AWG	KNOCK #01 ⁽⁴⁾	BTC Knock sensor input
36	24AWG	INPUT #15 ⁽¹⁾	Generic input; analogue or frequency ⁽¹⁾ ; 0-5V, -5V to +5V, 3kΩ (software pullup)
37	24AWG	INPUT #13 ⁽¹⁾	Generic input; analogue or frequency ⁽¹⁾ ; 0-5V, -5V to +5V, 3kΩ (software pullup)
38	24AWG	INPUT #11	Generic input; analogue or frequency; 0-5V, -5V to +5V, 3kΩ (software pullup)
39	24AWG	INPUT #09	Generic input; analogue or frequency; 0-5V, -5V to +5V, 3kΩ (software pullup)
40	-	DO NOT CONNECT	-
41	24AWG	INPUT #08	Analogue input 0-5V, 3kΩ software pullup to 5V
42	24AWG	INPUT #06	Analogue input 0-5V, 3kΩ software pullup to 5V
43	24AWG	INPUT #04	Analogue input 0-5V, 3kΩ software pullup to 5V
44	24AWG	INPUT #02	Analogue input 0-5V, 3kΩ software pullup to 5V

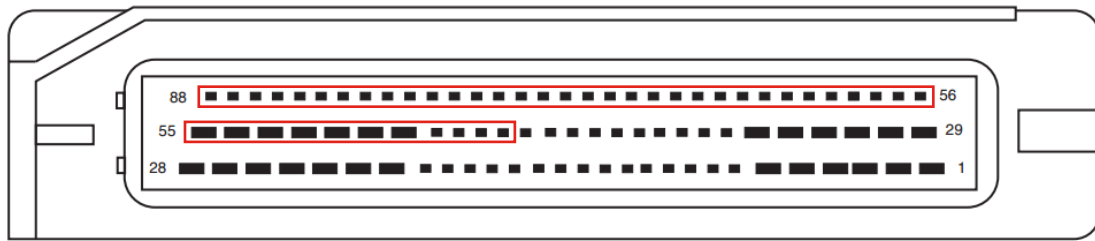

View looking into the 88 way connector highlighting pins 45-88 in red

Pin	Gauge	Signal Name	Signal Notes
45	24AWG	LAMBDA V #02 ⁽¹⁾ / CAN LO #03 ⁽¹⁾	BTC Lambda voltage signal [Vs] / CAN communication port 120Ω terminated
46	24AWG	INPUT #22	Thermistor input; analogue 0-5V with fixed 3kΩ pullup to 5V
47	22AWG	FUEL #16 ⁽²⁾ ⁽³⁾	Port fuel injector or low-side PWM 10A peak
48	24AWG	RS232 RX	RS232 receive
49	22AWG	FUEL #08	Port fuel injector or low-side PWM 10A peak
50	22AWG	FUEL #06	Port fuel injector or low-side PWM 10A peak
51	22AWG	FUEL #04	Port fuel injector or low-side PWM 10A peak
52	22AWG	FUEL #03	Port fuel injector or low-side PWM 10A peak
53	22AWG	FUEL #02	Port fuel injector or low-side PWM 10A peak
54	22AWG	FUEL #01	Port fuel injector or low-side PWM 10A peak
55	18AWG	POWER GROUND	ECU negative, must be engine ground and as short as possible
56	18AWG	BATTERY SUPPLY	ECU positive, must be as short as possible
57	18AWG	BATTERY SUPPLY	ECU positive, must be as short as possible
58	20AWG	H-BRIDGE #01 ⁽¹⁾	H-bridge, low-side or full bridge PWM, 20A peak
59	20AWG	H-BRIDGE #02 ⁽¹⁾	H-bridge, low-side or full bridge PWM, 20A peak
60	20AWG	H-BRIDGE #03 ⁽¹⁾	H-bridge, low-side or full bridge PWM, 20A peak
61	20AWG	H-BRIDGE #04 ⁽¹⁾	H-bridge, low-side or full bridge PWM, 20A peak
62	-	DO NOT CONNECT	-
63	24AWG	5V OUT #02	Regulated 5V sensor supply rail, maximum current capability of 100mA
64	24AWG	5V OUT #01	Regulated 5V sensor supply rail, maximum current capability of 100mA
65	24AWG	KNOCK GROUND ⁽¹⁾	BTC Knock sensor ground
66	24AWG	INPUT #20 / KNOCK #04 ⁽¹⁾	Analogue input 0-5V or BTC knock sensor input (set via software)
67	24AWG	SENSOR GROUND #02	Protected sensor ground
68	24AWG	INPUT #19 / KNOCK #03 ⁽¹⁾	Analogue input 0-5V or BTC knock sensor input (set via software)
69	24AWG	SENSOR GROUND #01	Protected sensor ground
70	-	DO NOT CONNECT	-
71	24AWG	INPUT #18	Analogue input 0-5V
72	24AWG	SENSOR GROUND #02	Protected sensor ground
73	24AWG	INPUT #17	Analogue input 0-5V
74	24AWG	SENSOR GROUND #01	Protected sensor ground
75	24AWG	LAMBDA I #02 ⁽¹⁾ / CAN HI #03 ⁽¹⁾	BTC Lambda current pump [Ip] / CAN communication port 120Ω terminated
76	24AWG	LAMBDA I #01	Lambda current pump [Ip]
77	24AWG	LAMBDA GROUND	Lambda ground [Vs/Ip]
78	24AWG	COMMS GROUND	Protected communication ground
79	24AWG	CAN LO #02	CAN communication port 120Ω terminated
80	24AWG	CAN HI #02	CAN communication port 120Ω terminated
81	24AWG	CAN LO #01	CAN communication port 120Ω terminated
82	24AWG	CAN HI #01	CAN communication port 120Ω terminated
83	24AWG	INPUT #24	Thermistor input; analogue 0-5V with fixed 3kΩ pullup to 5V
84	24AWG	INPUT #23	Thermistor input; analogue 0-5V with fixed 3kΩ pullup to 5V
85	24AWG	LAN RX+	Ethernet PC communication port
86	24AWG	LAN RX-	Ethernet PC communication port
87	24AWG	LAN TX+	Ethernet PC communication port
88	24AWG	LAN TX-	Ethernet PC communication port

Footnotes:

⁽¹⁾Relevant upgrade feature must be enabled to use signal

⁽²⁾Signal not available in R model

⁽³⁾Signal not available in RS model

Dimensions:

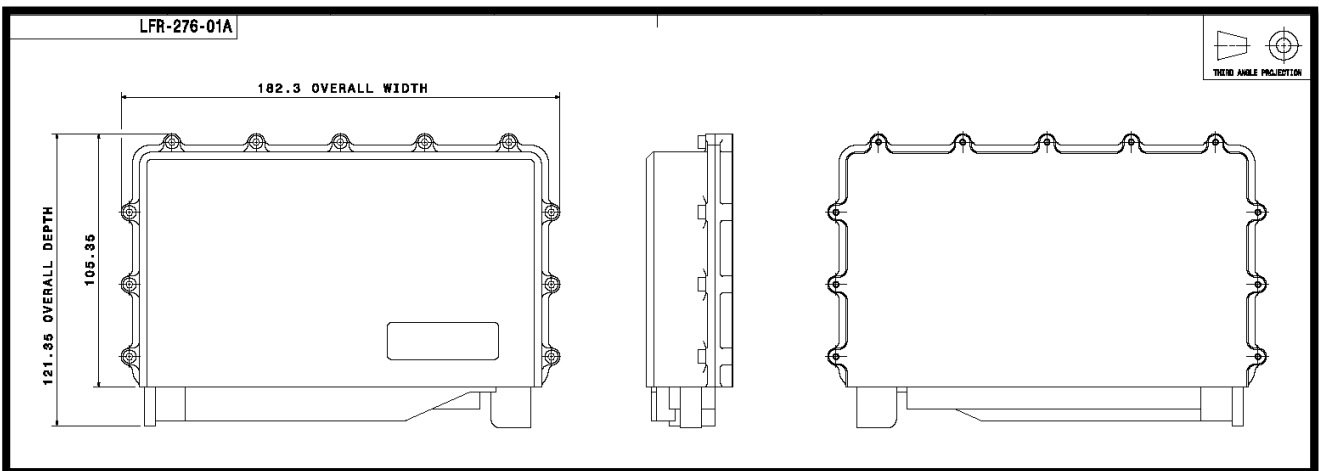
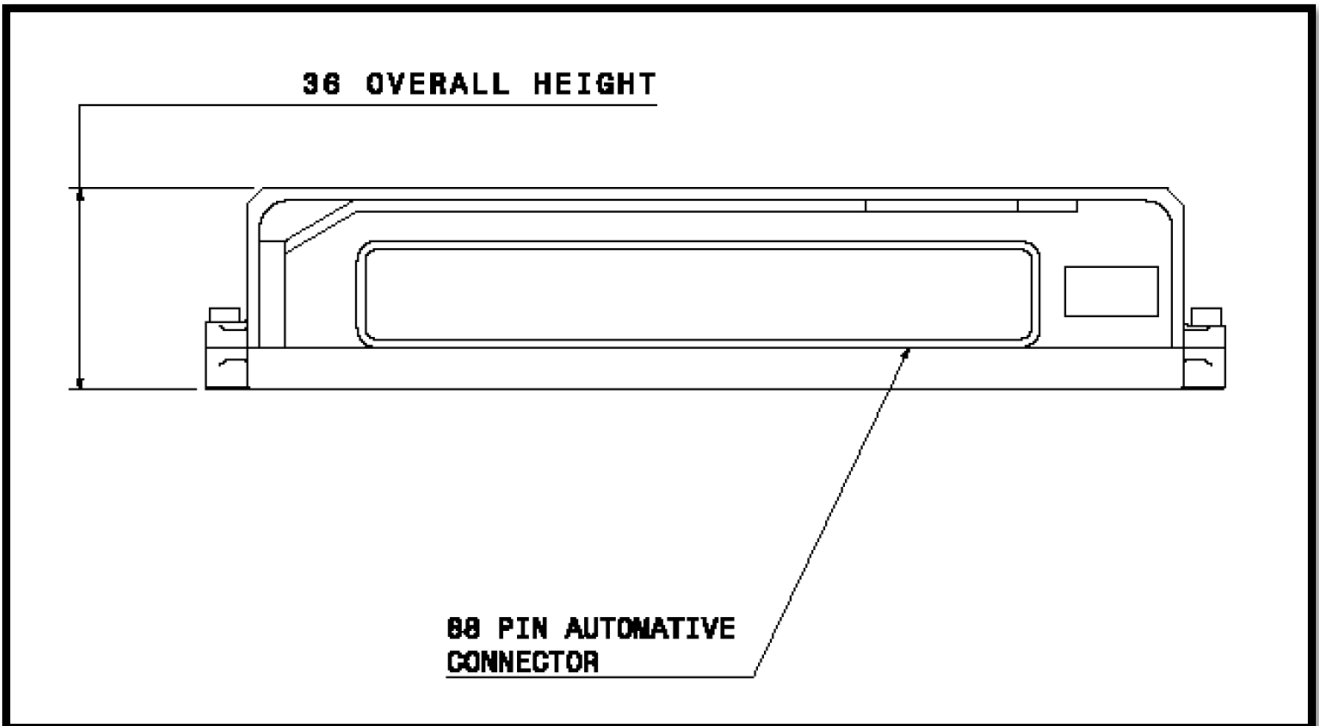

Warranty and Servicing:

- This equipment comes with a 1 year warranty against manufacturing defects and failures however misuse or damage will not be covered under warranty.
- Warranty may be extended on an annual basis via a system refurbishment scheme.
- This ECU contains a battery which can be returned to Life Racing for a replacement, a charge may be made for this service.