

F88 ECU Datasheet



The new version the popular F88 ECU has been upgraded to allow easy and cost effective control of Gasoline and Diesel direct injection engines from 1 to 8 cylinders. The F88 ECU can be used for both DI and non DI applications and with added new H-Bridge circuitry this ECU will directly control a high pressure fuel pump and drive by wire throttles. The internal memory has also been increased to 128MB as standard meaning this ECU can also act as the main logging system.

This twin processor unit uses a high speed RISC processor for code execution and an additional large FPGA for high speed engine position tracking, allowing scheduling code to be independent of signal patterns thus increasing flexibility, efficiency and accuracy under transient conditions. This powerful combination also allows advanced control algorithms yet remains easy to calibrate for the end user.

The F88 is designed to control complex modern engines including direct injection for gasoline and diesel fuels (in conjunction with an external GDI drive module). Standard strategies include, turbocharged, supercharged, drive by wire, quad vvt, vtec, gearbox, differential and many more. The internal data logging coupled with a unique crank and cam sync logger allows detailed analysis of inputs, control signals and fault diagnosis.

This powerful hardware is packaged within a lightweight CNC machined aluminium case designed to be installed in harsh motorsport environments.

Processing:

- Powerful RISC CPU for advanced strategy execution
- Custom synchronous FPGA processor for engine position tracking up to 25,000rpm

Outputs:

- 28 user configurable general purpose Pulse Width Modulated power outputs, including:
- 8 ignition coil outputs IGBT or TTL (Software configurable)
- 16 general PWM/Fuel injector outputs
- 2 full bridges also configurable as 4 half bridges or 4 PWMs (DbW & HDP-5)

Inputs:

- 24 user configurable general purpose analogue sensor inputs, including 16 bipolar, inductive or hall effect speed / engine position inputs
- 6 dedicated inputs, including:
- 2 acoustic knock sensor inputs
- 2 wideband (NTK) lambda sensor interface
- 2 K-type thermocouple sensor interfaces

Interfaces:

- 100 MHz full duplex Ethernet for calibration, configuration and data download
- 2 CAN 2.0B interfaces for communication with other controllers or logging systems
- RS232 serial interface for communication with other controllers or logging systems

Memory:

- 128MB battery backed internal logging memory
- Ultra-Fast data download via Ethernet
- Time/Date stamped data via real time clock

Power Supply:

- 6V to 30V input voltage range with reverse polarity protection
- 2 regulated 5V sensor supply output with individual short circuit protection
- Software configurable (5V to 12V) sensor supply output (e.g. for 10V load cells)
- 5 Separately protected sensor and communication ground input

Physical:

- 88 way Bosch / AMP sealed connector
- Sealed CNC machined anodised aluminium case
- Maximum dimension including the connector is 178mm x 122mm x 36mm
- Max operating temperature 85°C
- Total mass 485 grams

Available Upgrade Features:

- Adaptive Knock Control
- Diesel Control
- Direct Injection Pump Control
- Direct Motor Control
- Gearbox Control
- Traction Control
- Custom Security

Build Time Choice (BTC) Options:

- 12 Ignition Outputs
- CAN3 Replaces Second Lambda

Ordering Information:

Description	Part number
F88 ECU	ECU-A01
88Way Connector Kit	CON-B01
12 Ignition Outputs	ECU-BTC-12I
Adaptive Knock Control	ECU-FEAT-K
CAN3 Replaces Second Lambda	ECU-BTC-3C
Diesel Control	ECU-FEAT-D
Direct Injection Pump Control	ECU-FEAT-I
Direct Motor Control	ECU-FEAT-E
Gearbox Control	ECU-FEAT-G
Traction Control	ECU-FEAT-T

Wiring Information:

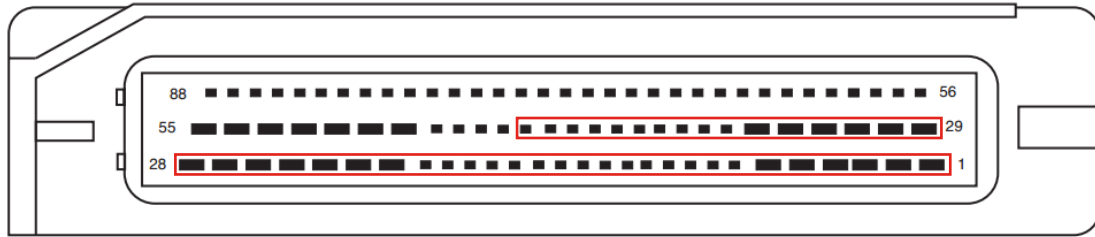

View looking into the 88 way connector highlighting pins 1-44 in red

Pin	Gauge	Signal Name	Signal Notes
1	18AWG	POWER GROUND	ECU negative, must be engine ground and as short as possible
2	20AWG	IGNITION #08	Ignition coil can be "NORMAL" or "TTL" (set via software) or low-side PWM
3	20AWG	IGNITION #07	Ignition coil can be "NORMAL" or "TTL" (set via software) or low-side PWM
4	20AWG	IGNITION #06	Ignition coil can be "NORMAL" or "TTL" (set via software) or low-side PWM
5	20AWG	IGNITION #05	Ignition coil can be "NORMAL" or "TTL" (set via software) or low-side PWM
6	22AWG	FUEL #10 / IGNITION #10 ⁽¹⁾	Port fuel injector or low-side PWM 10A peak / BTC of "NORMAL" Ignition coil
7	24AWG	KNOCK #02 ⁽¹⁾	Knock sensor input
8	24AWG	INPUT #16	Generic input; analogue or frequency; 0-5V, -5V to +5V, 3kΩ (software pullup)
9	24AWG	INPUT #14	Generic input; analogue or frequency; 0-5V, -5V to +5V, 3kΩ (software pullup)
10	24AWG	INPUT #12	Generic input; analogue or frequency; 0-5V, -5V to +5V, 3kΩ (software pullup)
11	24AWG	INPUT #10	Generic input; analogue or frequency; 0-5V, -5V to +5V, 3kΩ (software pullup)
12	24AWG	THERMO- #02	Thermocouple negative [K-Type]
13	24AWG	THERMO+ #02	Thermocouple positive [K-Type]
14	24AWG	INPUT #07	Generic input; analogue or frequency; 0-5V, -5V to +5V, 3kΩ (software pullup)
15	24AWG	INPUT #05	Generic input; analogue or frequency; 0-5V, -5V to +5V, 3kΩ (software pullup)
16	24AWG	INPUT #03	Generic input; analogue or frequency; 0-5V, -5V to +5V, 3kΩ (software pullup)
17	24AWG	INPUT #01	Generic input; analogue or frequency; 0-5V, -5V to +5V, 47kΩ (software pullup)
18	24AWG	LAMBDA V #01	Lambda voltage signal [Vs]
19	24AWG	INPUT #21	Thermistor input; analogue 0-5V with fixed 3kΩ pullup to 5V
20	22AWG	FUEL #15	Port fuel injector or low-side PWM 10A peak
21	24AWG	RS232 TX	RS232 transmit
22	22AWG	FUEL #07	Port fuel injector or low-side PWM 10A peak
23	22AWG	FUEL #05	Port fuel injector or low-side PWM 10A peak
24	20AWG	IGNITION #04	Ignition coil can be "NORMAL" or "TTL" (set via software) or low-side PWM
25	20AWG	IGNITION #03	Ignition coil can be "NORMAL" or "TTL" (set via software) or low-side PWM
26	20AWG	IGNITION #02	Ignition coil can be "NORMAL" or "TTL" (set via software) or low-side PWM
27	20AWG	IGNITION #01	Ignition coil can be "NORMAL" or "TTL" (set via software) or low-side PWM
28	18AWG	POWER GROUND	ECU negative, must be engine ground and as short as possible
29	18AWG	POWER GROUND	ECU negative, must be engine ground and as short as possible
30	22AWG	FUEL #14	Port fuel injector or low-side PWM 10A peak
31	22AWG	FUEL #13	Port fuel injector or low-side PWM 10A peak
32	22AWG	FUEL #12 / IGNITION #12 ⁽¹⁾	Port fuel injector or low-side PWM 10A peak / BTC of "NORMAL" Ignition coil
33	22AWG	FUEL #11 / IGNITION #11 ⁽¹⁾	Port fuel injector or low-side PWM 10A peak / BTC of "NORMAL" Ignition coil
34	22AWG	FUEL #09 / IGNITION #09 ⁽¹⁾	Port fuel injector or low-side PWM 10A peak / BTC of "NORMAL" Ignition coil
35	24AWG	KNOCK #01 ⁽¹⁾	Knock sensor input
36	24AWG	INPUT #15	Generic input; analogue or frequency; 0-5V, -5V to +5V, 3kΩ (software pullup)
37	24AWG	INPUT #13	Generic input; analogue or frequency; 0-5V, -5V to +5V, 3kΩ (software pullup)
38	24AWG	INPUT #11	Generic input; analogue or frequency; 0-5V, -5V to +5V, 3kΩ (software pullup)
39	24AWG	INPUT #09	Generic input; analogue or frequency; 0-5V, -5V to +5V, 3kΩ (software pullup)
40	24AWG	THERMO- #01	Thermocouple negative [K-Type]
41	24AWG	INPUT #08	Generic input; analogue or frequency; 0-5V, -5V to +5V, 3kΩ (software pullup)
42	24AWG	INPUT #06	Generic input; analogue or frequency; 0-5V, -5V to +5V, 3kΩ (software pullup)
43	24AWG	INPUT #04	Generic input; analogue or frequency; 0-5V, -5V to +5V, 3kΩ (software pullup)
44	24AWG	INPUT #02	Generic input; analogue or frequency; 0-5V, -5V to +5V, 3kΩ (software pullup)

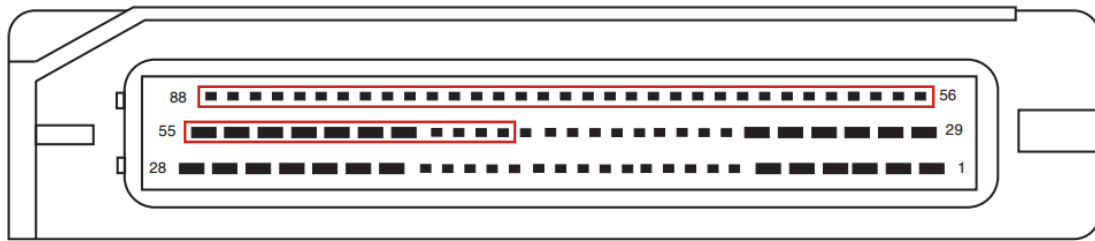

View looking into the 88 way connector highlighting pins 45-88 in red

Pin	Gauge	Signal Name	Signal Notes
45	24AWG	LAMBDA V #02 / CAN LO #03 ⁽¹⁾	Lambda voltage signal [Vs] / BTC CAN communication port 120Ω terminated
46	24AWG	INPUT #22	Thermistor input; analogue 0-5V with fixed 3kΩ pullup to 5V
47	22AWG	FUEL #16	Port fuel injector or low-side PWM 10A peak
48	24AWG	RS232 RX	RS232 receive
49	22AWG	FUEL #08	Port fuel injector or low-side PWM 10A peak
50	22AWG	FUEL #06	Port fuel injector or low-side PWM 10A peak
51	22AWG	FUEL #04	Port fuel injector or low-side PWM 10A peak
52	22AWG	FUEL #03	Port fuel injector or low-side PWM 10A peak
53	22AWG	FUEL #02	Port fuel injector or low-side PWM 10A peak
54	22AWG	FUEL #01	Port fuel injector or low-side PWM 10A peak
55	18AWG	POWER GROUND	ECU negative, must be engine ground and as short as possible
56	18AWG	BATTERY SUPPLY	ECU positive, must be as short as possible
57	18AWG	BATTERY SUPPLY	ECU positive, must be as short as possible
58	20AWG	H-BRIDGE #01 ⁽¹⁾	H-bridge, low-side or full bridge PWM, 20A peak
59	20AWG	H-BRIDGE #02 ⁽¹⁾	H-bridge, low-side or full bridge PWM, 20A peak
60	20AWG	H-BRIDGE #03 ⁽¹⁾	H-bridge, low-side or full bridge PWM, 20A peak
61	20AWG	H-BRIDGE #04 ⁽¹⁾	H-bridge, low-side or full bridge PWM, 20A peak
62	24AWG	10V OUT	Variable voltage supply pin, maximum current capability of 15mA
63	24AWG	5V OUT #02	Regulated 5V sensor supply rail, maximum current capability of 100mA
64	24AWG	5V OUT #01	Regulated 5V sensor supply rail, maximum current capability of 100mA
65	24AWG	KNOCK GROUND ⁽¹⁾	Knock sensor ground
66	24AWG	INPUT #20 / KNOCK #04 ⁽¹⁾	Analogue input 0-5V or knock sensor input (set via software)
67	24AWG	SENSOR GROUND #02	Protected sensor ground
68	24AWG	INPUT #19 / KNOCK #03 ⁽¹⁾	Analogue input 0-5V or knock sensor input (set via software)
69	24AWG	SENSOR GROUND #01	Protected sensor ground
70	24AWG	THERMO + #01	Thermocouple positive [K-Type]
71	24AWG	INPUT #18	Analogue input 0-5V
72	24AWG	SENSOR GROUND #02	Protected sensor ground
73	24AWG	INPUT #17	Analogue input 0-5V
74	24AWG	SENSOR GROUND #01	Protected sensor ground
75	24AWG	LAMBDA I #02 / CAN HI #03 ⁽¹⁾	Lambda current pump [Ip] / BTC CAN communication port 120Ω terminated
76	24AWG	LAMBDA I #01	Lambda current pump [Ip]
77	24AWG	LAMBDA GROUND	Lambda ground [Vs/Ip]
78	24AWG	COMMS GROUND	Protected communication ground
79	24AWG	CAN LO #02	CAN communication port 120Ω terminated
80	24AWG	CAN HI #02	CAN communication port 120Ω terminated
81	24AWG	CAN LO #01	CAN communication port 120Ω terminated
82	24AWG	CAN HI #01	CAN communication port 120Ω terminated
83	24AWG	INPUT #24	Thermistor input; analogue 0-5V with fixed 3kΩ pullup to 5V
84	24AWG	INPUT #23	Thermistor input; analogue 0-5V with fixed 3kΩ pullup to 5V
85	24AWG	LAN RX+	Ethernet PC communication port
86	24AWG	LAN RX-	Ethernet PC communication port
87	24AWG	LAN TX+	Ethernet PC communication port
88	24AWG	LAN TX-	Ethernet PC communication port

Footnotes:

⁽¹⁾Relevant upgrade feature must be enabled to use signal

Dimensions:

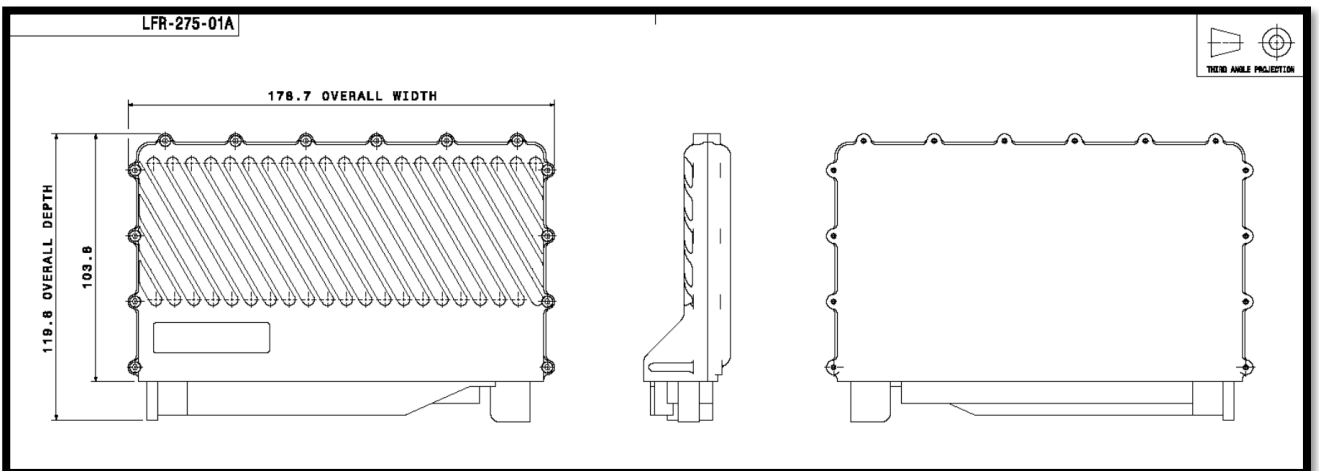
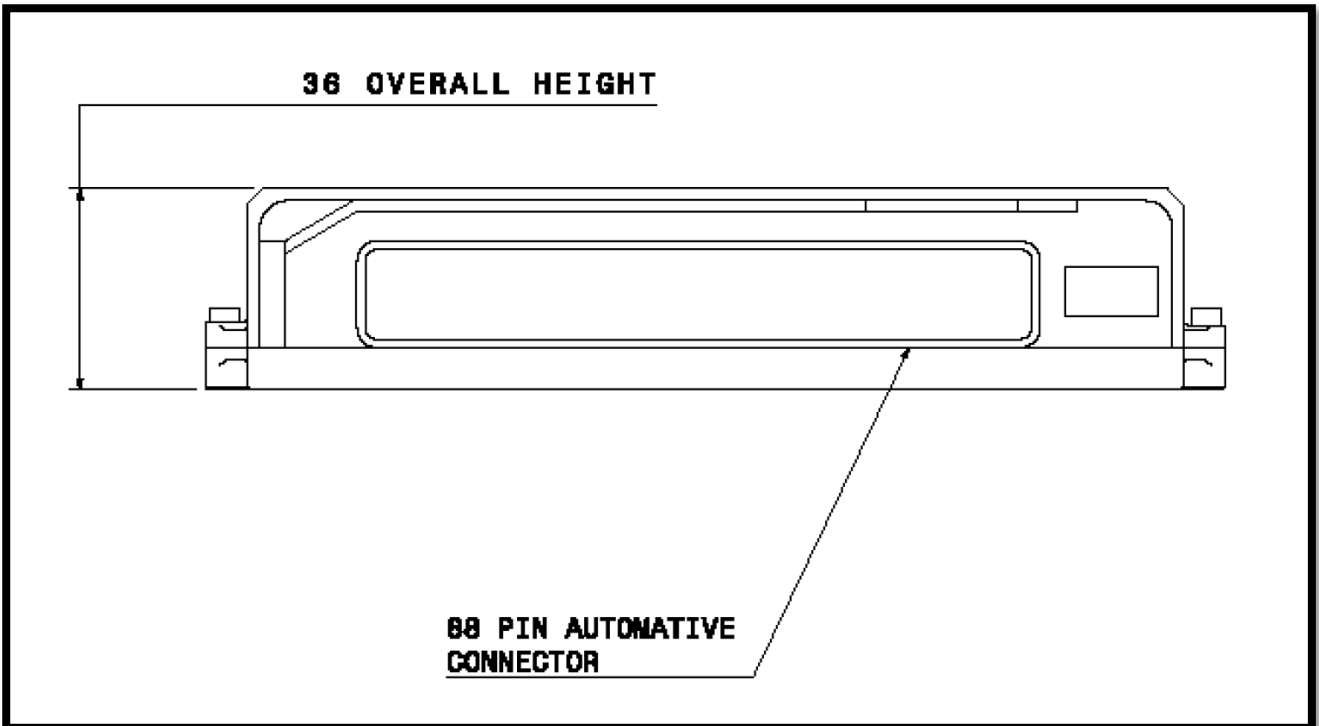

Warranty and Servicing:

- This equipment comes with a 1 year warranty against manufacturing defects and failures however misuse or damage will not be covered under warranty.
- Warranty may be extended on an annual basis via a system refurbishment scheme.
- This ECU contains a battery which can be returned to Life Racing for a replacement, a charge may be made for this service.